

Takumi

The Art of Productivity

V22 Vertical Machining Center



Heavy Duty High Torque Machine

- › 86.6 x 41.96 x 29.52 in (2,200 x 1,066 x 750 mm) travels
- › 86.6 x 40.35 in (2,200 x 1,025 mm) table working surface with 6,614 lbs (3,000 kg) maximum table capacity
- › Fast 551 x 551 x 472 in/min (14 x 14 x 12 m/min) rapids
- › 0.04 ~ 197 ipm (1 ~ 5000 mm/min) cutting feed rate
- › 6,000 rpm gear driven spindle with 488.6 ft-lbs of torque
- › Rigorous testing to ensure thermal stability
- › 24-station swing-arm ATC, random access
- › Wide, robust machine base
- › 4 box ways under the Y axis for maximum support
- › Rugged axis power transmission
- › Extended Y axis travel and work area
- › Large diameter, preloaded and pretensioned ballscrews with fine pitch for accurate motion control
- › 35 components on the machine are hand-scraped for fit
- › Wide front door openings and side door access
- › Takumi FANUC® H Control
- › AICC II for high feed rates with optimal cutting precision
- › 400 Block look ahead for fast contour milling
- › 56 work offsets for increased flexibility in job set up
- › 400 tool offset library with length and radius wear
- › Set Up Guidance function to decrease set up time
- › Programmable mirror image
- › Compact flash memory card slot and USB port
- › Rigid Tapping (M29)
- › 2 year machine parts warranty
- › 2 year control parts and labor warranty
- › Factory trained local service and 24/7 tech support

Specifications

| V22 | |
|---|---|
| Travel | |
| X-Axis | 86.6 in / 2,200 mm |
| Y-Axis | 41.96 in / 1,066 mm |
| Z-Axis | 29.52 in / 750 mm |
| Distance from Spindle Nose to Table | 7.87 ~ 37.4 in / 200 ~ 950 mm |
| Distance from Spindle Nose to Z-Axis Guide Ways | 44.09 in / 1,120 mm |
| Table | |
| Dimensions | 86.6 x 40.35 in / 2,200 x 1,025 mm |
| Max. Load | 6,614 lbs / 3,000 kg |
| T-slot (number x width x pitch) | 7 x .87 in on 5.91 in Centers / 5 x 22 mm on 150 mm Centers |
| Spindle | |
| Type | Gear |
| Spindle Speed | 6,000 rpm |
| Spindle Torque Peaks | 488.6 ft-lbs / 662.4 nm |
| Motor Power (cont./30 min) | 35 HP / 26 kW |
| Spindle Taper | CAT / BT 50 |
| Feed Rate | |
| Rapid Traverse (X/Y/Z) | 551 x 551 x 472 ipm / 14 x 14 x 12 m/min |
| Cutting Feed Rate | 0.04 ~ 197 ipm / 1 ~ 5,000 mm/min |
| Power (X/Y/Z) | 9.39 / 9.39 / 9.39 HP / 7.0 / 7.0 / 7.0 kW |
| ATC & Magazine | |
| ATC Type | Swing-Arm |
| Magazine Capacity | 24 tools |
| Maximum Tool Diameter (next pocket empty) | 4.33 / 8.66 in / 1110 / 220 mm |
| Maximum Tool Length | 11.81 in / 300 mm |
| Maximum Tool Weight | 33.07 lbs / 15 kg |
| Tool Shank | CAT 50 (BT 50 optional) |
| Space & System Requirements | |
| Pneumatic Pressure | 5 CFM @ 85-115 psi / 0.14 m3/min @ 6-8 bar |
| Electrical Power Consumption | 50 kva |
| Machine Net Weight | 54,013 lbs / 24,500 kg |
| Operating Dimensions (W x L x H) | 280.70 x 224.40 x 138.19 in / 7,130 x 5,700 x 3,510 mm |

Accessories

V22

Standard:

- › 435 psi coolant thru the spindle
- › Operator safety door switches
- › Spindle chiller
- › Programmable cutting air blow
- › Large coolant tank capacity
- › Programmable coolant wash down
- › Twin programmable belt-style lift up chip conveyors and carts
- › Wash down gun and air gun
- › Centralized automatic lubrication system
- › Manual pulse generator (MPG)
- › Ethernet and RS-232C interface
- › 4th axis interface cables and connectors
- › Electrical cabinet heat exchanger
- › Toolbox
- › Leveling bolts and pads
- › Operator manuals
- › Full enclosure

- › Work light
- › 3-light indicator lamp

Optional:

- › Oil skimmer
- › Oil mist device
- › Oil mist collector
- › Coolant filtration
- › 1 Gigabyte Data Server
- › Memory Card editing
- › Part probe measurement system
- › Tool probe measurement system
- › 4th axis rotary table
- › BT 50 tool holder conversion

Layout

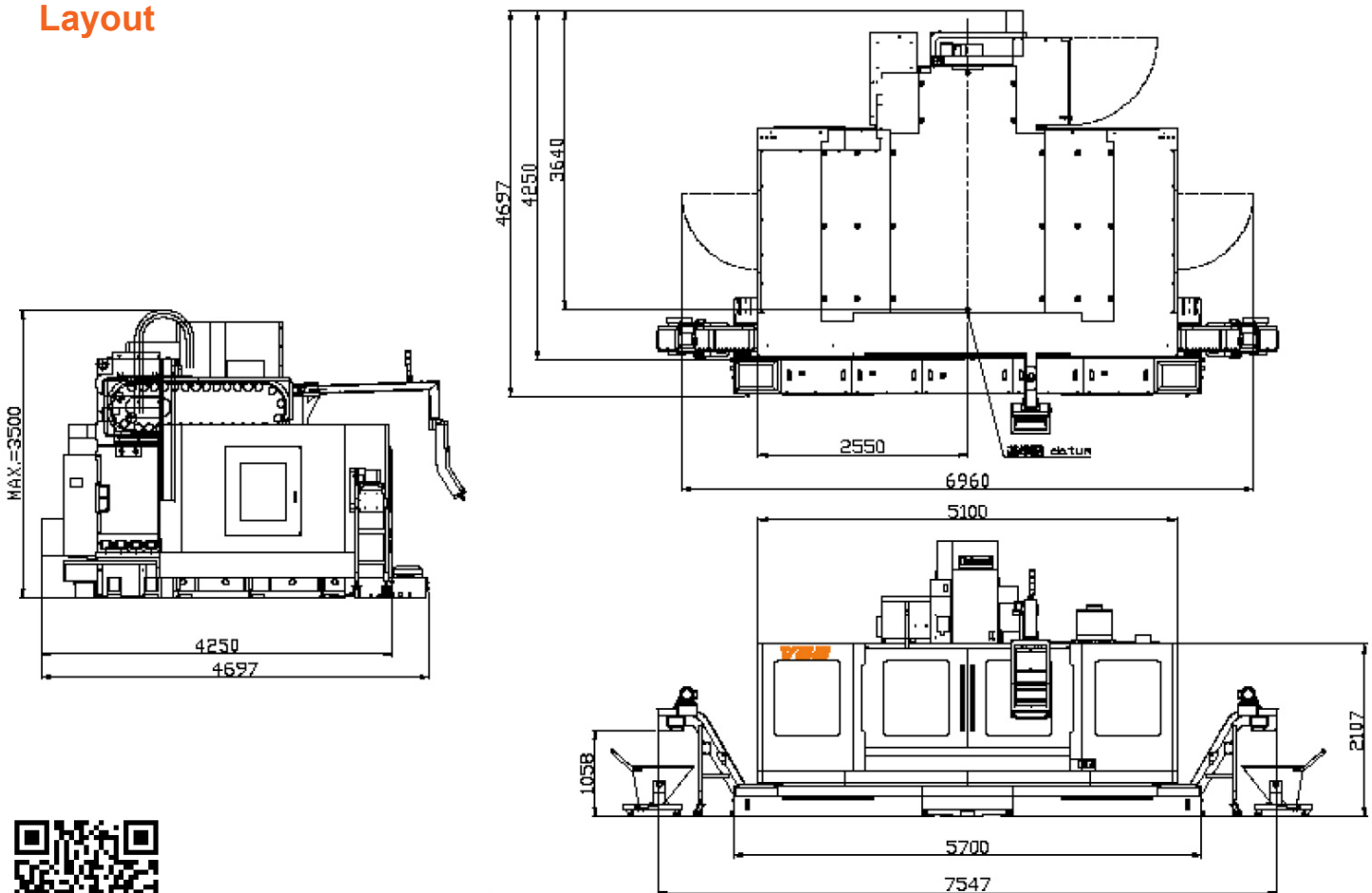

Takumi

7220 Winton Drive Indianapolis, IN 46268
1.844.302.3792 | TAKUMIUSA.com

A division of Hurco Companies, Inc.

Information may change without notice. Some machines shown with options T003 rev 3.06.19